

Technical data sheet



Product features

Food display island chilled GN 4-1/1 Hemlock

Model	SAP Code	00012118
--------------	-----------------	----------



- Buffet type: LIME - chilled, static cooling, shallow
- Device properties: Chilled
- Number of GN / EN: 4
- GN / EN size in device: GN 1/1
- GN device depth: 30
- Minimum device temperature [°C]: 4
- Maximum device temperature [°C]: 8

SAP Code	00012118	Loading	230 V / 1N - 50 Hz
Net Width [mm]	1494	Number of GN / EN	4
Net Depth [mm]	650	GN / EN size in device	GN 1/1
Net Height [mm]	1288	GN device depth	30
Net Weight [kg]	95.00	Minimum device temperature [°C]	4
Power electric [kW]	0.247	Maximum device temperature [°C]	8

Technical data sheet



Technical drawing

Food display island chilled GN 4-1/1 Hemlock

Model

SAP Code

00012118

A= ELECTRICAL CONNECTION
 D= WATER DISCHARGE ø16
 E= GAS CONNECTION ø6 ø8
 F= WATER BOX

GN	L
3/1	1169
4/1	1494
6/1	2144

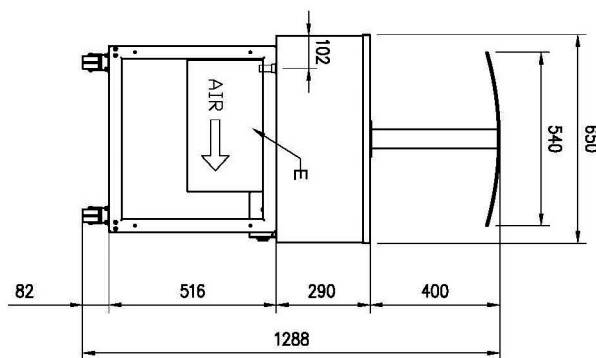
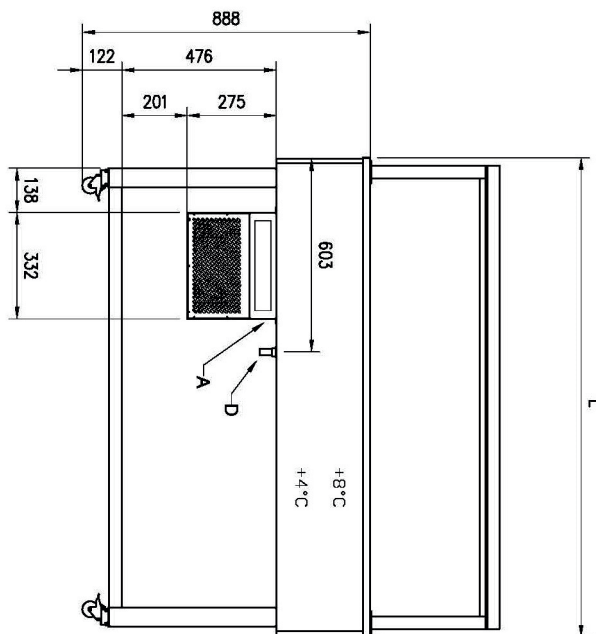
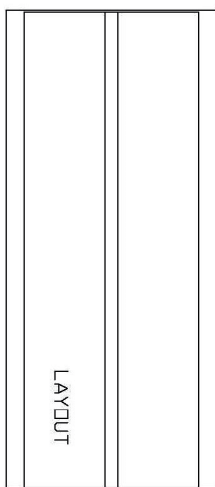

FLAT

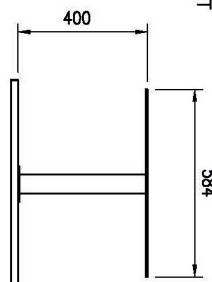

SERVICE

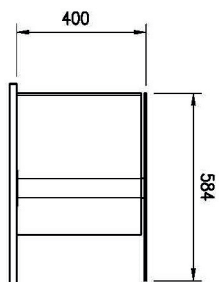

TRADITION

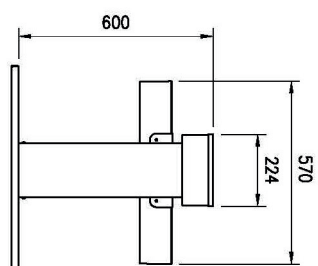

Technical data sheet



Product benefits

Food display island chilled GN 4-1/1 Hemlock

Model

SAP Code

00012118

1

Static cooling

simultaneous use of direct injection and boiler, maintenance of 100% humidity, or its regulation

- less drying of food
- more economical

2

Depth 30mm

the possibility of placing plates and trays

- variability of use

3

All-stainless steel construction

harmless to health for contact with food
robustness

- perfect sanitation
- long service life

4

Rounded corners

basins without sharp edges and corners

- higher hygienic safety
- time saving due to easy cleaning

5

LED lighting

basins without sharp edges and corners

- economical lighting
- attractive appearance

6

Travel wheels

portable buffet table

- greater flexibility in dispensing
- possibility of use at banquets
- easier and safer handling

7

Breathing galley with trigger

galerka made of hygienic Plexiglas with motorized displacement

- hygienic food protection
- the possibility of sealing before dispensing - extending the shelf life of food

Technical data sheet



Technical parameters

Food display island chilled GN 4-1/1 Hemlock

Model

SAP Code

00012118

1. SAP Code:

00012118

2. Net Width [mm]:

1494

3. Net Depth [mm]:

650

4. Net Height [mm]:

1288

5. Net Weight [kg]:

95.00

6. Gross Width [mm]:

1558

7. Gross depth [mm]:

714

8. Gross Height [mm]:

1100

9. Gross Weight [kg]:

115.00

10. Device type:

Electric unit

11. Buffet type:

LIME - chilled, static cooling, shallow

12. Device properties:

Chilled

13. Exterior color of the device:

Hemlock

14. Power electric [kW]:

0.247

15. Loading:

230 V / 1N - 50 Hz

16. Number of GN / EN:

4

17. GN / EN size in device:

GN 1/1

18. GN device depth:

30

19. Minimum device temperature [°C]:

4

20. Maximum device temperature [°C]:

8